

## AUTOMATIC VEHICLE COLLISION PREVENTION AND WARNING USING INFRARED / ULTRASONIC

BALWINDER SINGH<sup>1</sup>, HARJOT KAUR<sup>2</sup>, AVNINDERPAL SINGH<sup>3</sup>, BALVIR SINGH<sup>4</sup>

<sup>1,2,3</sup> PURSUING M-TECH IN LCET, <sup>4</sup> PURSUING B-TECH IN DBIEM

<sup>1,2</sup>VPO AITIANA, TEHSIL RAIKOT, <sup>3</sup>VPO LAMME, TEHSIL JAGRAON, <sup>4</sup>H N.5677 AGWARDALA, JAGRAON DISTRICT LUDHIANA (PUNJAB)

balwinder.sdh@gmail.com, purewal\_harjot2@yahoo.co.in, avninderpal@gmail.com, balvir\_panesar@yahoo.com

**Abstract**— Our Project proposes a two or more vehicle collision warning. Emerging infrared / ultrasonic technologies for vehicle detection are promising to dramatically reduce the number of road accidents by providing early warnings. One major technical challenge addressed in this our project is to achieve low-latency in delivering emergency warnings in various road situations. Based on a careful analysis of application requirements, we design an effective hardware, service differentiation mechanisms and methods for emergency warning. Simulation results demonstrate that the proposed hardware achieves to delivering emergency warnings and efficient usage in different road situations. It is designed for low-power consumption allowing batteries to essentially last forever. The distance measurement process by using Ultrasonic / Infrared sensors. Our project will provide three different messages that are safe, careful and warning on LCD display with audio message.

\*\*\*\*\*

### I. INTRODUCTION

Our this project Automatic vehicle collision PREVENTION AND warning using INFRA-RED / ultrasonic is based on the infrared waves as well as on ultrasonic waves. As we know in foggy conditions especially in winter season it is very difficult to see the object in front of you and sometimes collision is occurred and result is the death of many persons. Keeping in mind this type of conditions we are making this project. As we know infrared light has the property of reflection. When the infrared light is emits it strikes with the object and after strike with the object this infrared light is comes back toward the emitting source. This system consists a microcontroller which controls the whole process. In this system one LCD is used to display the information about the distance of the second vehicle and one buzzer which give the warning indication when vehicle is too much closer our vehicle. In this system we can also measure the distance between two vehicles .If the distance between two vehicles is less than the required distance then on LCD written message is appeared. Therefore this device helps us to put the necessary action before any type of miss happening.

### II. INFRARED RAYS

Infrared rays have the wavelength longer than the visible light wavelength. Actually the Infrared rays are the electromagnetic radiations extending from the nominal red edge of the visible spectrum at 0.74 micrometers ( $\mu\text{m}$ ) to 300  $\mu\text{m}$ . This range of wavelengths corresponds to a

frequency range of approximately 1 to 400 THz. Infrared light is used in industrial, scientific, and medical applications. Infrared imaging is used extensively for military and civilian purposes. Military applications include target acquisition, surveillance, and night vision, homing and tracking. Non-military uses include thermal efficiency analysis, environmental monitoring, industrial facility inspections, remote temperature sensing, short-ranged wireless communication, spectroscopy, and weather forecasting. IR data transmission is also employed in short-range communication among computer peripherals and personal digital assistants. These devices usually conform to standards published by IrDA, the Infrared Data Association. Remote controls and IrDA devices use infrared light-emitting diodes (LEDs) to emit infrared radiation which is focused by a plastic lens into a narrow beam. The beam is modulated, i.e. switched on and off, to encode the data. The receiver uses a silicon photodiode to convert the infrared radiation to an electric current. It responds only to the rapidly pulsing signal created by the transmitter, and filters out slowly changing infrared radiation from ambient light. For the transmission and reception of signal we are using long range Infrared transmitters and receivers. The range of Infrared transmitters and receivers is up to 50 meters. We need these long range Infrared transmitters and receivers because for safety point of view we require minimum distance between two vehicles is at least 50 meters when they are coming from two opposite sides.

### III. ULTRASONIC RAYS

Ultrasonic waves have the frequency very high. Human ear can listen ultrasonic waves but with some desired range of frequency. This is because human ear can listen the frequency range from 20 kHz to 20 Hz and the frequency range of ultrasonic waves is very high and it's out of range of human ear. Ultrasound is a cyclic sound pressure wave with a frequency greater than the upper limit of the human hearing range. Ultrasound is used in many different fields. Ultrasonic devices are used to detect objects and measure distances. Ultrasonic imaging is used in human and veterinary medicine. In non-destructive testing of products and structures, ultrasound is used to detect invisible flaws. Industrially, ultrasound is used for cleaning and for mixing, and to accelerate chemical processes. Organisms such as bats and porpoises use ultrasound for locating prey and obstacles. Ultrasonic's is the application of **ultrasound**. For ultrasonic detection there is no need oh line of sight communication and there is no need of sensors in contact with each other .This is one more advantages to get the information about the object and provide the exact location of the coming vehicle. For sensing purposes we are using two types of sensors i.e.

1. Non-Contact Sensors
2. Motion Sensors

#### 1. Non Contact Sensors:-

An ultrasonic level or sensing system requires no contact with the target. Both continuous wave and pulsed systems are used. The principle behind a pulsed-ultrasonic technology is that the transmit signal consists of short bursts of ultrasonic energy. After each burst, the electronics looks for a return signal within a small window of time corresponding to the time it takes for the energy to pass through the vessel. Only a signal received during this window will qualify for additional signal processing.

#### 2. Motion Sensors:-

Motion sensors are the type of sensors which detects the objects which are in motion and these sensors also measures the speed of coming object and measure the distance of the coming object.

### IV. INFRARED/ULTRASONIC DEVICE

Our system is working with infrared rays and ultrasonic rays. Therefore when any object comes in the range of device it will gives the warning and on LCD 'CAREFULL' message is displayed and when the object is much closer then beep of our system is starts beeping and gives the warning message to alert the driver. Below is block diagram of the device. In this one microcontroller which controls the

whole process and two sensors which senses the position of the vehicle .For displaying the message LCD is used. In this we also used the sensors on the sides of the vehicles for the purposes of to sense the object which are coming from the sides. Power supply units provide the necessary power to the system.

### V. CONCLUSION

This system reduces the chances of collision of vehicles at very large extent. Moreover this is very cheap and easy to install any type of vehicles without paying anything to anyone.

### VI. BLOCK DIAGRAM

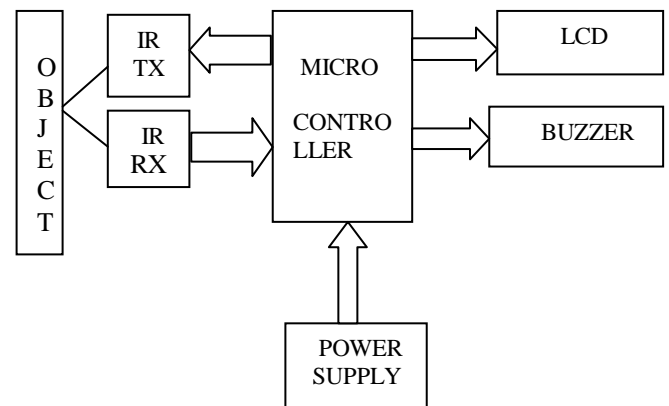

### VII. REFERENCES

- [1] 8051 Microcontroller and embedded system by Muhammad Ali Mazidi
- [2] Let's C by Yashwant Kanetkar
- [3] Programming in Ansi C by E.Balagurusamy
- [4] Dr. S. C. Liew. "Electromagnetic Waves"
- [5] www.google.co.in