

Simulation of Harmonics Filters to Reduce Harmonics Distortion Using MATLAB

Shubhangi A. Bhatkar
Dept. of Electrical Engg.
SSGMCE, Shegaon.

Asha D. Rahane
Dept. of Electrical Engg
MGI-COET, Shegaon

Radhika S. Dhawale
Dept. of Electrical Engg
MGI-COET, Shegaon

Email: bhatkarshubhangi15@gmail.com

Sayali N. Sawarkar
Dept. of Electrical Engg
MGI-COET, Shegaon

Namita R. Chavan
Dept. of Electrical Engg
MGI-COET, Shegaon

Abstract- Harmonic voltages and currents in an electric power system are a result of non-linear electric loads. Harmonic frequencies in the power grid are a frequent cause of power quality problems. Harmonics in power systems result in increased heating in the equipment and conductors, misfiring in variable speed drives, and torque pulsations in motors. Reduction of harmonics is considered desirable. Harmonic filters can be mainly classified into two: passive filtering techniques and active filtering techniques. The system is used in this paper is industrial power system. The harmonic problem in industrial power supply system detailed design analysis of harmonic filter and case study for filter design are analyzed and simulated by Matlab/Simulink.

Keywords: Harmonics, Power Supply System, Harmonics Filters, MATLAB/Simulink.

I. INTRODUCTION

The use of non-linear loads in industry and domestic application such as variable electrical drives, computers, furnaces, electronic ballast, etc. have led to the flow of load currents encompassing odd harmonics, which are integral multiples of the fundamental frequency.[1] The electric quality power defines power quality “ the measure, analysis and improvement of bus voltages, usually a load bus voltages, to maintain that voltage to be sinusoid at rated voltages and frequency.” Power Quality (PQ) issues were considered only in the past few years ago. Earlier this problem was only considered by the power engineers. Recently only the community deals about the PQ problems because of their awareness and the standard power stations maintain. Even in the industries only the recent generation people are trained in these power quality areas. There are various PQ issues related to power system. Some of the power quality issues are reactive power balance, voltage imbalance, harmonics, transients and interruption. Due to these issues, harmonics play a major role in the PQ. In electrical terminology harmonics can be defined as components that are present with fundamental waveform of

voltage or current and that are integer multiples of fundamental frequency. Harmonics are generally caused due to non-linear nature of loads which inject harmonic currents in the AC system and increase overall reactive power demanded by the equivalent load. A harmonic filter is used to eliminate the harmonics. There are three basic types of harmonics filters namely Passive, Active and Hybrid harmonic filters. A lot of work, surveying and analysis were done so as to design a suitable filter to reduce harmonics for power quality improvement.[2]

II. HARMONICS AND ITS EFFECT

Harmonics are sinusoidal voltages or currents having frequencies that are whole multiples of the frequency at which the supply system is designed to operate (e.g. 50Hz or 60 Hz). Harmonics are simply a technique to analyze the current drawn by computers, electronic ballasts, variable frequency drives and other equipment which have modern “transformer-less” power supplies.

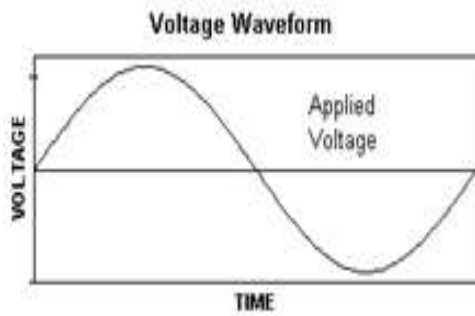

Fig.1: Voltage Waveforms

Ohm's Law states that current equals voltage divided by resistance. Expressed mathematically $I=V/R$. Expressed graphically, the current ends up being another sine wave, since the resistance is a constant number. Ohm's Law dictates that the frequency of the current wave is also 60 Hertz. In the real world, this is true; although the two sine waves may not align perfectly (as a power factor) the current wave will indeed be a 60 Hertz sine wave.

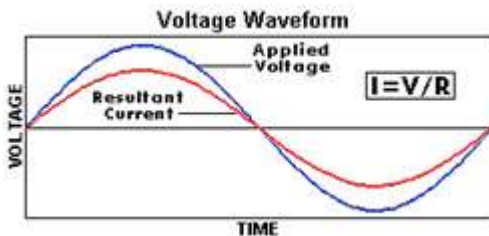

Fig.2: Voltage and time waveform

Since an applied voltage sine wave will cause a sinusoidal current to be drawn, systems which exhibit this behaviour are called linear systems. Incandescent lamps, heaters and motors are linear systems. Computers, variable frequency drives, electronic ballasts and uninterruptable power supply systems are non-linear systems. In these systems, the resistance is not a constant and in fact, varies during each sine wave. This occurs because the resistance of the device is not a constant. The resistance in fact, changes during each sine wave.

III.HARMONICS FILTERS TECHNIQUES

Harmonic filters can be mainly classified into two:

Passive filtering techniques

Active filtering techniques

A. Active Filtering Techniques

An active filter is a type of analog electronic filter that uses active components such as an amplifier. Amplifiers included in a filter design can be used to improve the performance and predictability of a filter, while avoiding the need for inductors (which are typically expensive compared to other components).

B. Passive Filtering Technique

Passive filters are very much helpful for mitigation of harmonic component & used traditionally. Continuous

development has been reported in this technique for betterment of filter. It helps to achieve the optimum utilization with reduced rating & cost. The use of passive filter in the mitigation of harmonics in 3 phase system uses the utilization of reactor & capacitor.

This is one of the most common methods for control of harmonic distortion in industry is the use of passive filtering techniques that make use of single- tuned or band-pass filters.

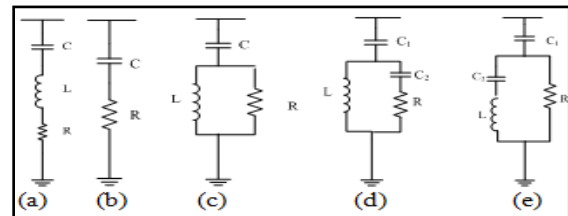

Fig. 3 (a) Single- tuned (b) 1st order high-pass (c) 2nd order high-pass (d) 3rd order high-pass (e) C-type.

Passive implementations of linear filters are based on combinations of resistors (R), inductors (L) and capacitors (C). These types are collectively known as passive filters, because they do not depend upon an external power supply and/or they do not contain active components such as transistors.[3]

1) Advantages and Disadvantages of Passive Filter Over Active Filter

a) Advantages of Passive Filter over Active Filter:

- Less costly than active filter.
- Passive filters can be used for small loads as well as large loads in a power system.

b) Disadvantages of Passive Filter over Active Filter:

- Circuit becomes bulky as inductors are used.

IV. SIMULATION RESULTS AND DISCUSSION

The simulation results are obtained through Power System toolboxes in SIMULINK. Power quality is inspected with the waveform distortion condition of voltage and current at the source. Besides, Fast Fourier Transform (FFT) analysis tool of MATLAB Simulation software measures the participating rate of harmonic in the system.

A. Case 1-Model Running without Harmonic Filters

In the Simulink model, the HVDC rectifier is built up from two 6-pulse thyristor bridges connected in series. The converter is connected to the system with a 1200MVA three-phase transformer (three windings). A 1000MW resistive load is connected to the DC side through a 0.5H smoothing reactor as shown in Fig.4.

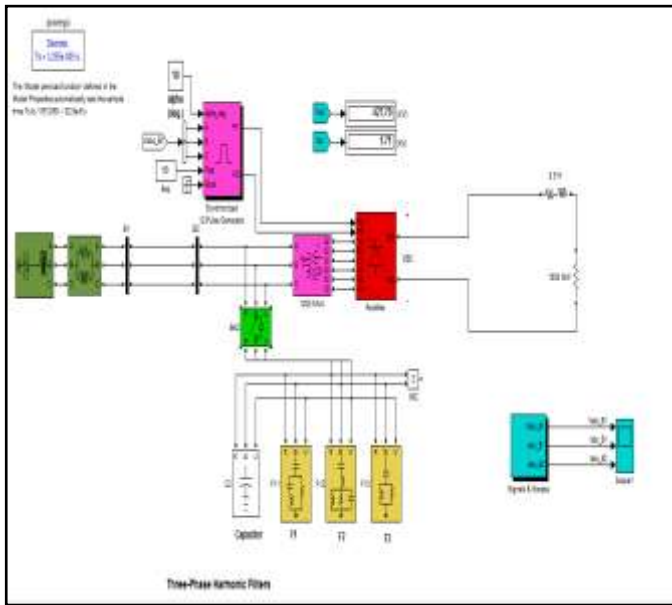

Fig.4 MATLAB based model without three-phase passive filters.

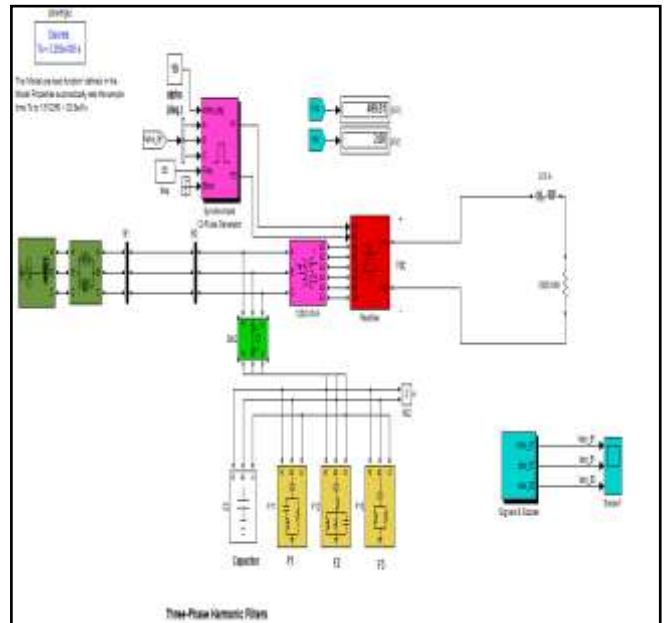

Fig.6 MATLAB based model with three-phase passive filters.

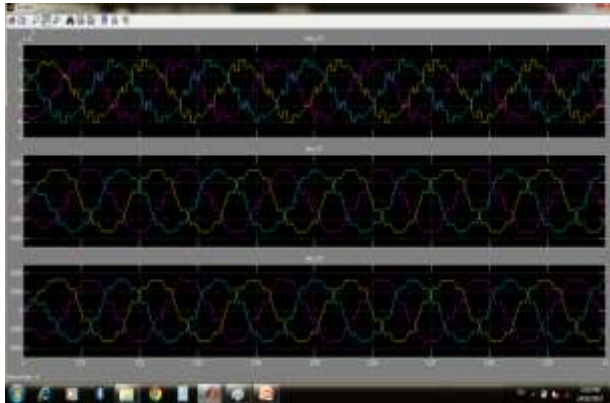

Fig 5.Voltage and current waveform without passive filters

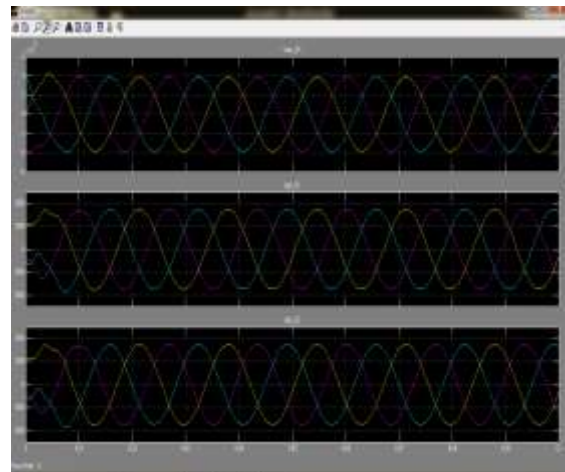

Fig.7Voltage and current waveform with passive filters

Fig.7 shows the voltage and current waveform when filter is connected after bus B2.

Fig.5 shows the waveform of voltage and current on bus B1 and current waveform on bus B2. Fig 4 represent MATLAB based model in which there is no passive filter connected in the system so harmonics are present in the given and output waveforms are shown in above fig.5.

B. Case 2-Model Running with Harmonic Filters

MATLAB based model with three-phase passive Filters is as shown in Fig. 6. When the model is running with load on condition with harmonic filters installation, the status of voltage and current waveforms are shown in Fig.7. As shown in Fig.7, voltage and current waveforms change to smooth by the effect of harmonic filters installation.[3]

V. FFT ANALYSIS

The ratio of the root mean square of the harmonics content to the rms value of the fundamental quantity, expressed as percent of the fundamental is total harmonic distortion.

The total harmonics distortion i.e THD is very useful quantity for many applications. It can provide a good idea of how much extra heat will be realized when a distorted voltage is applied across a resistive load. Likewise, it can give an indication of the additional losses caused by current flowing through conductor.

Total Harmonics Distortion i.e THD of voltage on bus B1 without passive filter is 17.78% which is shown in below fig.8

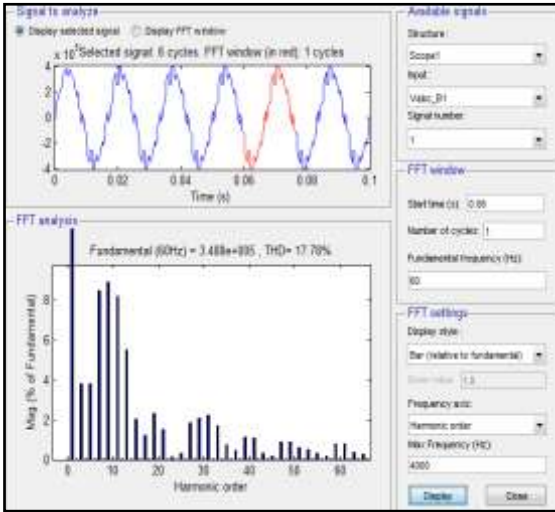

Fig.8 FFT analysis without filter of voltage

Total Harmonics Distortion i.e THD of current on bus B1 without passive filter is 12.59% which is shown Fig.9.

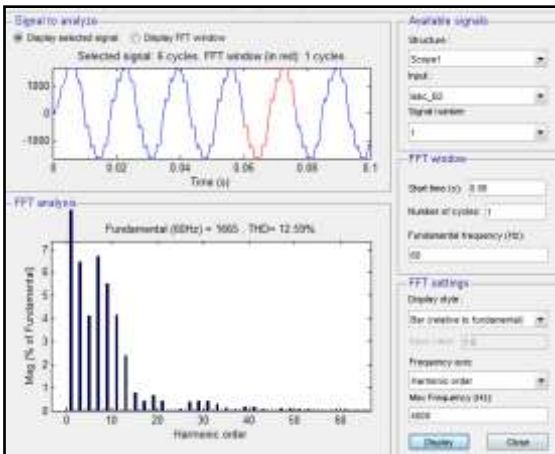

Fig.9 FFT analysis without filter of current

Total Harmonics Distortion i.e THD of voltage on bus B1 with passive filter is 0.88% which is shown in below fig.10.

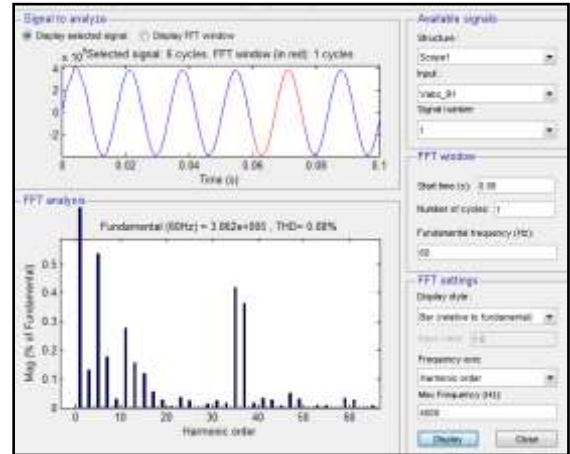

Fig.10 FFT analysis with filter of voltage

Total Harmonics Distortion i.e THD of current on bus B1 with passive filter is 0.70% which is shown below fig.10.

As described in Fig. 10 and Fig.11, voltage and current distortions are disappeared to reach almost pure sinusoidal sine wave situation and the different rates of harmonic distortion with and without three phase harmonic filters are listed in Table I.

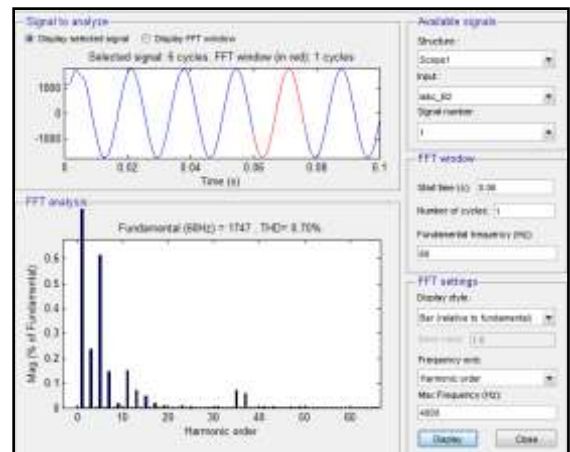

Fig.8 FFT analysis with filter of current

TABLE I: THD PERCENTAGE COMPARISON

Parameters	%THD without filters	%THD with Filters
Voltage	17.78	0.88
Current	12.59	0.70

VI.ADVANTAGES

- Total harmonic distortion of current obtained is 12.59% at 60 Hz.
- Three winding transformer is use. The third winding (data winding) offers the closed path to the third harmonic current.
- Economical and essential way for harmonic reduction is use.

- d) Reduces 5th,7th,11th and higher order harmonic and harmonic filter reduces the THD of the current injected in the system from 9% to 0.7%.
- e) By using this system there is improvement in power quality.
- f) Higher pulse (12 pulse) rectifier is used in this system. 12 plus rectifier generated higher order harmonics which are not harmful to the system.

VII. DISADVANTAGES

- a) All filters are kept active all the time.
- b) This protection scheme is use only for low and medium industrial system.

VII.FUTURE SCOPE

The future analysis can be done by analyzing the behaviour of the system with different types of loading or by using digital filter or study the behaviour of current and voltage. If we used the active filter instead of passive filter, this filters check which harmonics (3rd, 5th, 7th up to higher order) is present in the system and only that filter we have to kept active, in future work the automatic switching of circuit breaker can be done.

VIII.CONCLUSION

The effectiveness of the three-phase harmonic passive filters has been achieved as the result of harmonic components reduction that exists in a power system with a chosen non-linear load. In this paper three-phase passive filter not only reduce 11th harmonic but also considering for distortion of 5th and 7th harmonic of the system where harmonics are produced due to a twelve-pulse converter. The distortion of power supply current was distorted to a satisfactory level with THD=0.70% and voltage with THD=0.88%.

REFERENCES

- [1] G .Narayan, et.al, "A shunt active filter for reactive power compensation and harmonic mitigation", The 7th International Conference on Power Electronics, IEEE, pp.672-676, 2008.
- [2] "Design of Active Filters to reduce Harmonics for Power Quality Improvement" 2015 International conference on computation of power, energy, information and communication.
- [3] "Analysis of Harmonic Reduction by using Passive Harmonic Filters" ISSN 2319-8885 Vol.03,Issue.45 December-2014, Pages:9142-9147 International Journal of Scientific Engineering and Technology. The Mon Aye1, Soe Win Naing2
- [4] "Study on Mitigation of Harmonics by Using Passive Filter and Active Filter" International Journal of Innovative Research in Computer and Communication Engineering An ISO 3297: 2007 Certified Organization Vol.3, Special Issue 5, May 2015 International

Conference On Advances in Computer & Communication Engineering (ACCE - 2015) on 5th & 6th May 2015, Organized by Department of CSE, Vemana Institute of Technology, Bengaluru, India Copyright to IJIRCCCE www.ijirccce.com 254

[5] "Harmonic Analysis Using Shunt Active Filter" Journal Of Information, Knowledge And Research In Electrical Engineering

[6] "IEEE Recommended Practices and Requirements for Harmonic Control in Electrical Power Systems." American National Standard (ANSI) IEEE SM 519-1992 (Revision of IEEE SM 519-1981)n